

EBONY

PROFESSIONAL VIEW CAMERAS



“Perfection is within your reach.”

EBONY SV45 series *

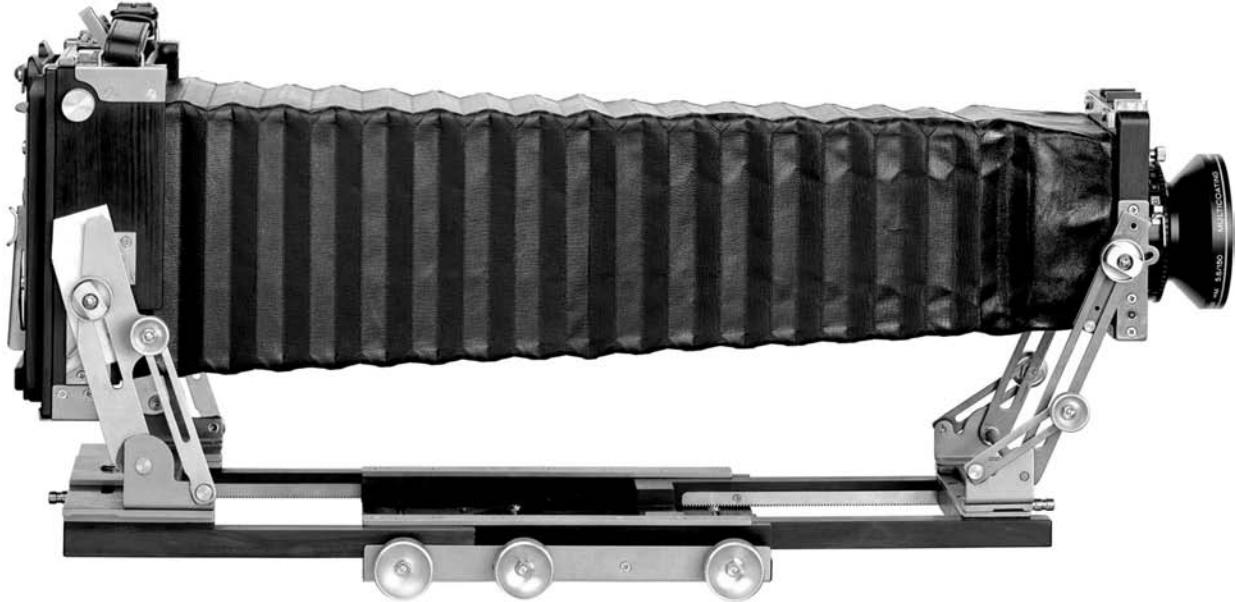

590mm maximum extension with tilts and rise



Wide-angle bellows may be used with 35-210mm lenses



Extremely compact



Wide-angle configuration with tilts and rise

Front Movements

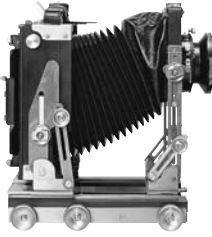
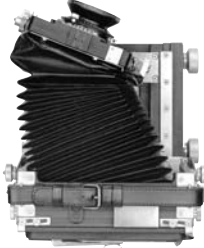
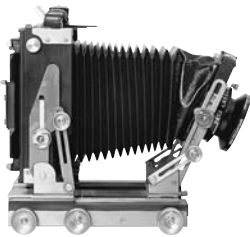
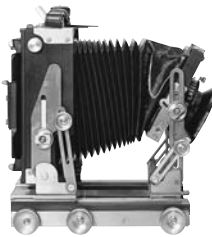
<p>Rise 42 mm, Fall 23 mm</p> 	<p>Shift 32 mm + 32 mm Swing 20° + 20°</p> 	<p>Base tilt forward 30°, backward 90°</p> 	<p>Center tilt 30° + 30°</p> 
---	--	---	--

Back Movements

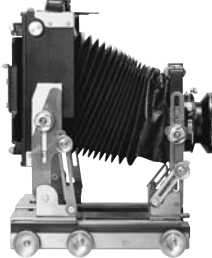
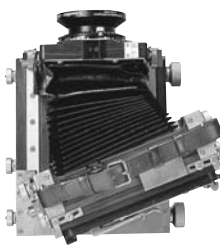
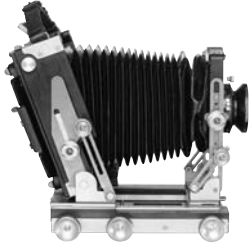
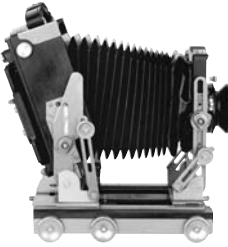
<p>Rise 45 mm</p> 	<p>Shift 50 mm + 50 mm Asymmetrical swing 20° + 20°</p> 	<p>Base tilt forward 90°, backward (bed drop) 30°</p> 	<p>Asymmetrical tilt 20° + 20°</p> 
---	---	--	--

* Model depicted: SV45U2

EBONY SV45 series

Ebony's legendary series of folding 4x5 cameras.

The SV45U2, SV45U and SV45TE are superbly crafted from quarter-sawn ebony heartwood, one of nature's hardest, strongest and most stable construction materials. This extremely dense and straight-grained wood is aged for over 20 years before it is cut, and finished with a premium grade oil to retain its unique natural lustre.

The SV45Ti is constructed with the same care and attention to detail from 20-year-old quarter-sawn mahogany heartwood, and finished with exquisite Lacquer Japan ('urushi').

As with all Ebony cameras, the metal parts of the SV45 series are made of solid titanium - harder, stronger and lighter than stainless steel. The uniquely thin and supple yet durable calfskin bellows are hand-made to Ebony's specifications. The hand-strap is made of genuine cordovan leather. All parts are made to unequalled standards of precision and meticulously assembled by hand. Every camera is then rigorously checked and tested by Ebony's team of craftsmen to ensure total accuracy and reliability.

The Ebony SV45 series are cameras without compromise - in materials, craftsmanship or range of abilities.

- Absolutely rigid construction: no vibration or sway, even at maximum extension. Complete stability is assured.
- The movements, precision and rigidity of a view camera with the portability of a field camera
- Base and center tilts at both front and back (Asymmetrical tilts and swings replace center tilts and swings on back standard of SV45U and SV45U2 allowing perfect focus to be maintained during adjustments.)
- Huge triple-draw bellows extension enabling use of 35mm-800mm lenses. (Universal bellows, allowing greater range of movements with wide-angle lenses, replace standard bellows on SV45U2. Interchangeable wide-angle bellows also available as optional accessory for all SV cameras.)
- 35/38mm lens may be used with recessed lensboard
- Foldable, with 30° bed drop
- Compatible with Linhof-type 4x5 lensboards
- **Accepts both 4x5 International Standard and 6x9 Graphic Standard roll film holders (Horseman, Mamiya RB67 etc.): format reducing adapter required for 6x9 roll film or instant film holders.**

SPECIFICATIONS

CAMERA TYPE		Folding view camera	
FORMAT		International Standard 4x5 inch. Accepts all International Standard sheet film holders: Polaroid 405, 545, 550, Fuji Instant MS45, PA45, and all Graphic Standard roll film holders.	
CONSTRUCTION MATERIALS		Ebony (SV45U2, SV45U, SV45TE) or mahogany (SV45Ti) and titanium	
FOCUSING SYSTEM		Triple-draw rack and pinion (front and back focusing)	
LENSBOARD		4x5 Linhof-type	
CAMERA BACK		Interchangeable vertical/horizontal International Standard	
FOCUSING SCREEN		Fresnel lens with 10mm grid, protective glass	
MOVEMENTS (levers lock swings and shifts, knobs lock all other movements)	FRONT	Rise 42mm, Fall 23mm, Shift 32mm+32mm, Swing 20°+20°, Base tilt forward 30°, backward 90°, Center tilt 30° + 30°	
	BACK	SV45U2	Rise 45mm, Shift 50mm+50mm, Asymmetrical Swing 20°+20°, Base tilt forward 90°, backward (bed drop) 30°, Asymmetrical tilt 20°+20°
		SV45U	Rise 45mm, Asymmetrical swing 20°+20°, Base tilt forward 90°, backward (bed drop) 30°, Asymmetrical tilt 20°+20°
		SV45TE/Ti	Rise 45mm, Shift 50mm+50mm, Swing 20°+20°, Base tilt forward 90°, backward (bed drop) 30°, Center tilt 20°+20°
BED	Drop 30°		
ZERO ("NULL") POSITION RESET		Front swings and asymmetrical/center tilts: zero detents Back rise: lowest position Front rise/fall: zero position alignment points Shifts: zero position on scale Base tilts: zero position notches	
MIN/MAX BELLOWS EXTENSION		SV45U2	85mm (55mm with tilts and rise) - 510mm (590mm with tilts and rise)
		SV45U	85mm (55mm with tilts and rise) - 445mm (530mm with tilts and rise)
		SV45TE/Ti	85mm (55mm with tilts and rise) - 445mm (530mm with tilts and rise)
USABLE LENSES		35mm* - 800mm telephoto *35mm - 47mm lenses (except 47XL) require recessed lensboard	
SPIRIT LEVEL	FRONT	One-way	
	BACK	Two-way with mirror	
WEIGHT / DIMENSIONS		SV45U2	3.15 kg / 22.5 (h) x 20.5* (w) x 10 (l) cm
		SV45U	2.7 kg / 19 (h) x 21* (w) x 10 (l) cm
		SV45TE	2.7 kg / 19 (h) x 21* (w) x 10 (l) cm
		SV45Ti	2.1 kg / 19 (h) x 21* (w) x 10 (l) cm * including knobs

EBONY45SU



365mm maximum extension



Wide-angle bellows may be used with 35-210mm lenses



Front Movements

Rise 70 mm, Fall 30 mm

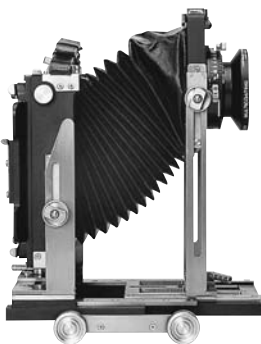

Shift 40 mm + 40 mm

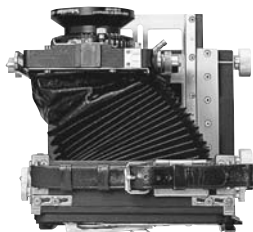

Swing 45° + 45°

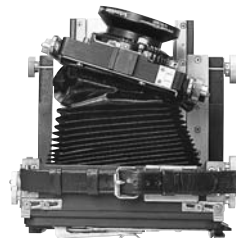

Center tilt 30° + 30°

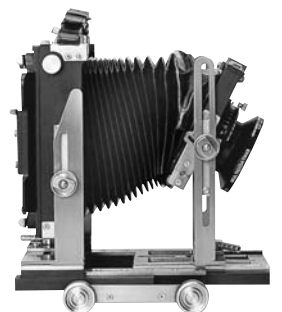

EBONY45SU

The Ebony 45SU is a non-folding 4x5 inch view camera with asymmetrical rear tilts and swings. It is hand-made from 20 year-old quarter-sawn ebony heartwood and solid titanium, and features calfskin bellows and a genuine cordovan leather hand-strap. A unique quadruple-draw rack and pinion focusing system allows the use of up to 500mm telephoto lenses

- Ebony and titanium construction: no vibration or sway, even at maximum extension. Complete stability is assured.
- The movements, precision and rigidity of a view camera with the portability of a field camera
- Asymmetrical tilts and swings allow perfect focus to be maintained during adjustments
- Unique quadruple-draw bellows extension, enabling use of 35mm-500mm lenses
- Universal bellows replace standard bellows, facilitating use of wide-angle lenses. (Interchangeable wide-angle bellows available as optional accessory)
- 35/38mm lens may be used with recessed lensboard
- Compatible with Linhof-type 4x5 lensboards
- **Accepts both 4x5 International Standard and 6x9 Graphic Standard roll film holders (Horseman, Mamiya RB67 etc.): format reducing adapter required for 6x9 roll film or instant film holders.**

SPECIFICATIONS

CAMERA TYPE		Non-folding view camera
FORMAT		International Standard 4x5 inch. Accepts all International Standard sheet film holders: Polaroid 405, 545, 550, Fuji Instant MS45, PA45, and all Graphic Standard roll film holders.
CONSTRUCTION MATERIALS		Ebony and titanium
FOCUSING SYSTEM		Quadruple-draw rack and pinion (front and back focusing)
LENSBOARD		4x5 Linhof-type
CAMERA BACK		Interchangeable vertical/horizontal International Standard
FOCUSING SCREEN		Fresnel lens with 10mm grid, protective glass
MOVEMENTS (levers lock swings and shifts, knobs lock all other movements)	FRONT	Rise 70mm, Fall 30mm, Shift 40mm+40mm, Swing 45°+45°, Center tilt 30°+30°
	BACK	Rise 40mm, Shift 50mm+50mm, Asymmetrical Swing 20°+20°, Asymmetrical tilt 20°+20°
ZERO ("NULL") POSITION RESET		Front swings and front/back tilts: zero detents Back rise: lowest position Front rise/fall: zero position alignment points Shifts: zero position on scale
MIN/MAX BELLOWS EXTENSION		58 - 365mm
USABLE LENSES		35mm* - 500mm (telephoto) *35mm - 47mm lenses (except 47XL) require recessed lensboard
SPIRIT LEVEL	FRONT	One-way
	BACK	Two-way with mirror
WEIGHT / DIMENSIONS		2.6kg / 23.0 (h) x 20.5* (w) x 12.0 (l) cm *including knobs

Back Movements

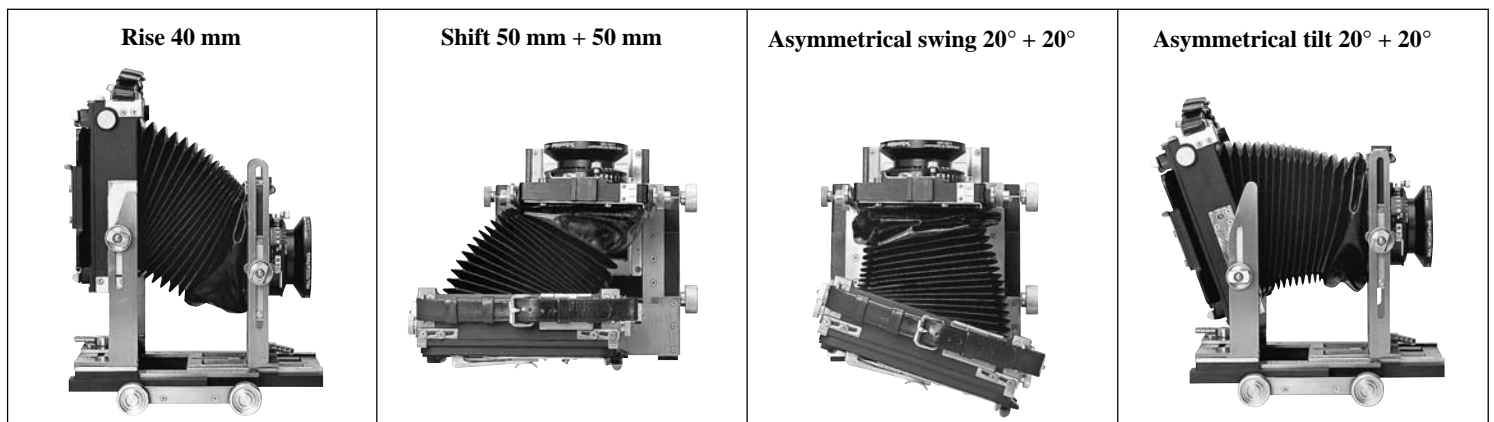

EBONY 45S

A lightweight multipurpose view camera of the non-folding type with extensive movements and a wide range of usable lenses. The 45S is hand-made from 20 year-old quarter-sawn ebony heartwood and solid titanium, and features extremely supple calfskin bellows and a genuine cordovan leather hand-strap. The unique bellows design allows full movements with wide lenses without causing any bellows shadow.

- Ebony and titanium construction: no vibration or sway, even at maximum extension. Complete stability is assured.
- The movements, precision and rigidity of a view camera with the portability of a field camera
- 60mm+60mm back shift, enabling panoramic photography without lens movement
- 38mm lens may be used with recessed lensboard
- Triple-draw bellows extension
- Compatible with Linhof-type 4x5 lensboards
- Optional Ebony extension back 452 and/or extension tubes enable the use of longer lenses.
- **Accepts both 4x5 International Standard and 6x9 Graphic Standard roll film holders (Horseman, Mamiya RB67 etc.): format reducing adapter required for 6x9 roll film or instant film holders.**



SPECIFICATIONS

CAMERA TYPE		Non-folding view camera	
FORMAT		International Standard 4x5 inch. Accepts all International Standard sheet film holders: Polaroid 405, 545, 550, Fuji Instant MS45, PA45, and all Graphic Standard roll film holders.	
CONSTRUCTION MATERIALS		Ebony and titanium	
FOCUSING SYSTEM		Triple-draw rack and pinion (front and back focusing)	
LENSBOARD		4x5 Linhof-type	
CAMERA BACK		Interchangeable vertical/horizontal International Standard	
FOCUSING SCREEN		Fresnel lens with 10mm grid, protective glass	
MOVEMENTS (levers lock swings and shifts, knobs lock all other movements)	FRONT	Rise 50mm, Fall 25mm, Shift 38mm+38mm, Swing 45°+45°, Center tilt 20°+20°	
	BACK	Rise 50mm, Shift 60mm+60mm, Swing 20°+20°, Center tilt 20°+20°	
ZERO ("NULL") POSITION RESET		Swings and center tilts: zero detents Back rise: lowest position Front rise/fall: zero position alignment points Shifts: zero position on scale	
MIN/MAX BELLOWS EXTENSION		60 - 270mm	
USABLE LENSES		38mm* - 400mm (telephoto) *38mm - 47mm lenses require recessed lensboard	
SPIRIT LEVEL	FRONT	One-way	
	BACK	Two-way with mirror	
WEIGHT / DIMENSIONS		2.1kg / 21.0 (h) x 20.5* (w) x 12.0 (l) cm *including knobs	

EBONY 23S

A lightweight multipurpose view camera of the non-folding type with extensive movements and a wide range of usable lenses. The 23S is hand-made from 20 year-old quarter-sawn ebony heartwood and solid titanium, and features extremely supple calfskin bellows and a genuine cordovan leather hand-strap. The unique bellows design allows full movements with wide lenses without causing any bellows shadow.

- Ebony and titanium construction: no vibration or sway, even at maximum extension. Complete stability is assured.
- The movements, precision and rigidity of a view camera with the portability of a field camera.
- 40mm+40mm back shift, enabling panoramic photography without lens movement
- 45/47mm lens may be used with recessed lensboard
- Triple-draw bellows extension
- 6x9 Polaroid/Fuji film may be used with Instant Film holder GP (available as optional accessory)
- Compatible with Linhof-type 4x5 lensboards
- Optional Ebony extension back 692 and/or extension tubes enable the use of longer lenses.
- **Accepts 6x9 Graphic Standard roll film holders (Horseman, Mamiya RB67 etc.) Roll film holders may be removed without dismounting focusing screen.**



SPECIFICATIONS

CAMERA TYPE		Non-folding view camera
FORMAT		Graphic Standard 6 x 9 cm (2 x 3 inch). Accepts all Graphic Standard roll film holders.
CONSTRUCTION MATERIALS		Ebony and titanium
FOCUSING SYSTEM		Triple-draw rack and pinion (front and back focusing)
LENSBOARD		4 x 5 Linhof-type
CAMERA BACK		Interchangeable vertical/horizontal Graphic Standard
FOCUSING SCREEN		Fresnel lens with 10mm grid, protective glass
MOVEMENTS (levers lock swings and shifts, knobs lock all other movements)	FRONT	Rise 50mm, Fall 25mm, Shift 38mm+38mm, Swing 45°+45°, Center tilt 20°+20°
	BACK	Rise 40mm, Shift 40mm+40mm, Swing 20°+20°, Center tilt 20°+20°
ZERO ("NULL") POSITION RESET		Front swings and center tilts: zero detents Back rise: lowest position Front rise/fall: zero position alignment points Shifts: zero position on scale
MIN/MAX BELLOWS EXTENSION		65 - 275mm
USABLE LENSES		45mm* - 400mm (telephoto) *45mm, 47mm lenses require recessed lensboard
SPIRIT LEVEL	FRONT	One-way
	BACK	Two-way with mirror
WEIGHT / DIMENSIONS		1.8kg / 18.0 (h) x 17.5* (w) x 12.0 (l) cm *including knobs

EBONY SV23

The 6x9 version of Ebony's classic folding camera. The SV23 is constructed from 20 year-old quarter-sawn ebony heartwood and solid titanium. The uniquely supple yet durable calfskin bellows are hand-made to Ebony's specifications. The hand-strap is made of genuine cordovan leather. It has an amazing range of features for such a light and compact camera.

- Ebony and titanium construction: no vibration or sway, even at maximum extension. Complete stability is assured.
- The movements, precision and rigidity of a view camera with the portability of a field camera
- Base and center tilts at both front and back
- Huge triple-draw bellows extension, enabling use of 35mm to 720mm lenses. (Interchangeable wide-angle bellows available as optional accessory)
- 35/38mm lens may be used without restricting movements
- Foldable, with 30° bed drop
- Compatible with Linhof-type 4x5 lensboards
- **Accepts 6x9 Graphic Standard roll film holders (Horseman, Mamiya RB67 etc.) Roll film holders may be removed without dismounting focusing screen.**

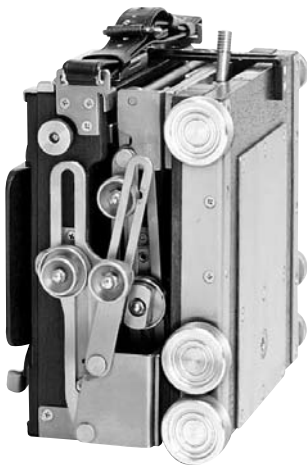

SPECIFICATIONS

CAMERA TYPE		Folding view camera
FORMAT		Graphic Standard 6x9cm (2x3 inch). Accepts all Graphic Standard roll film holders.
CONSTRUCTION MATERIALS		Ebony and titanium
FOCUSING SYSTEM		Triple-draw rack and pinion (front and back focusing)
LENSBOARD		4x5 Linhof-type
CAMERA BACK		Interchangeable vertical/horizontal Graphic Standard
FOCUSING SCREEN		Fresnel lens with 10mm grid, protective glass
MOVEMENTS (levers lock swings and shifts, knobs lock all other movements)	FRONT	Rise 42mm, Fall 17mm, Shift 32mm+32mm, Swing 20°+20°, Base tilt forward 30°, backward 90°, Center tilt 30° + 30°
	BACK	Rise 40mm, Swing 10°+10°, Base tilt forward 90°, backward (bed drop) 30°, Center tilt 20° + 20°
	BED	Drop 30°
ZERO ("NULL") POSITION RESET		Swings and center tilts: zero detents Back rise: lowest position Front rise/fall: zero position alignment points Shifts: zero position on scale Base tilts: zero position notches
MIN/MAX BELLOWS EXTENSION		75mm (55mm with tilts and rise) - 420mm (495mm with tilts and rise)
USABLE LENSES		35mm* - 720mm (telephoto) * 35mm - 47mm lenses (except 47XL) require recessed lensboard
SPIRIT LEVEL	FRONT	One-way
	BACK	Two-way with mirror
WEIGHT / DIMENSIONS		2.0kg / 15.0 (h) x 18.0* (w) x 9.5 (l) cm *including knobs

EBONY SV57 series*

The 5x7 version of Ebony's classic folding camera. Constructed entirely of quarter-sawn Honduran mahogany heartwood (SV57, SV57U), or quarter-sawn ebony heartwood (SV57E, SV57UE), and solid titanium. The supple yet durable calfskin bellows are hand-made to Ebony's specifications. The hand-strap is made of genuine cordovan leather. The SV57U and SV57UE feature asymmetrical tilts and swings on the back standard for easier and faster focusing.

- Extremely rigid construction: no vibration or sway, even at maximum extension. Complete stability is assured.
 - The movements, precision and rigidity of a view camera with the portability of a field camera.
 - Base and center tilts at both front and back (Asymmetrical tilts and swings replace center tilts and swings on back standard of SV57U and SV57UE allowing perfect focus to be maintained during adjustments.)
 - Huge, triple-draw bellows extension, enabling use of 65mm to 800mm lenses. (Universal bellows now replace standard bellows, facilitating use of wide-angle lenses. Interchangeable wide-angle bellows available as optional accessory)
 - Compatible with Sinar-type lensboards, Linhof adapter board included
 - Foldable, with 30° bed drop
- Accepts both 4x5 International Standard and 6x9 Graphic Standard roll film holders (Horseman, Mamiya RB67 etc.) with 5x7->4x5 reducing back: format reducing adapter required for 6x9 roll film or instant film holders.

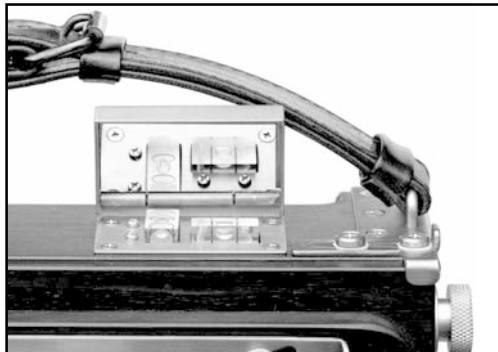

Spirit levels with mirror

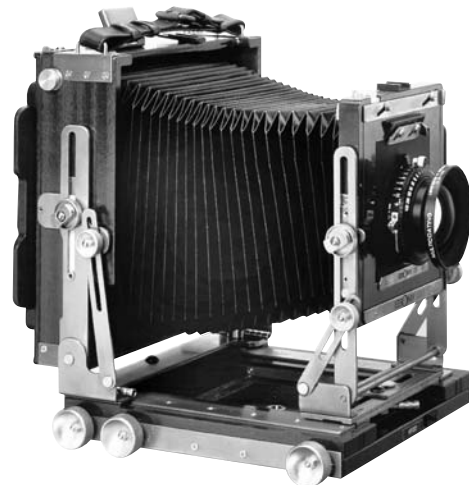

SPECIFICATIONS

CAMERA TYPE		Folding view camera	
FORMAT		International Standard 5x7 inch	
CONSTRUCTION MATERIALS		Mahogany (SV57, SV57U) or ebony (SV57E, SV57UE) and titanium	
FOCUSING SYSTEM		Triple-draw rack and pinion (front and back focusing)	
LENSBOARD		Sinar-type (Linhof adapter board included)	
CAMERA BACK		Interchangeable vertical/horizontal International Standard	
FOCUSING SCREEN		Ground glass with 10mm grid	
MOVEMENTS (levers lock swings and shifts, knobs lock all other movements)	FRONT	Rise 60mm, Fall 30mm, Shift 50mm+50mm, Swing 20°+20°, Base tilt forward 30°, backward 90°, Center tilt 20° + 20°	
	BACK	SV57U	Rise 60mm, Asymmetrical swing 20°+20°,
		SV57UE	Base tilt forward 90°, backward (bed drop) 30°, Asymmetrical tilt 20° + 20°
	BED	SV57	Rise 60mm, Swing 20°+20°,
SV57E		Base tilt forward 90°, backward (bed drop) 30°, Center tilt 20° + 20°	
ZERO ("NULL") POSITION RESET		Front swings and center/asymmetrical tilts: zero detents Back rise: lowest position Front rise/fall: zero position alignment points Shifts: zero position on scale Base tilts: zero position notches	
MIN/MAX BELLOWS EXTENSION		105mm (60mm with tilts and rise) - 605mm (715mm with tilts and rise)	
USABLE LENSES		65-800mm (telephoto). 4x5 reducing back: 58XL on flat board, 47XL on recessed board)	
SPIRIT LEVEL	FRONT	One-way	
	BACK	Two-way with mirror	
WEIGHT / DIMENSIONS	SV57U	3.0 kg / 23.5 (h) x 26.0* (w) x 10.5 (l) cm	
	SV57UE	4.0 kg / 23.5 (h) x 26.0* (w) x 10.5 (l) cm	
	SV57	3.0 kg / 23.5 (h) x 26.0* (w) x 10.5 (l) cm	
	SV57E	4.0 kg / 23.5 (h) x 26.0* (w) x 10.5 (l) cm	*including knobs

* Model depicted: SV57

EBONY SV810 series*

The 8x10 version of Ebony's classic folding camera. Constructed entirely of quarter-sawn Honduran mahogany heartwood (SV810, SV810U), or quarter-sawn ebony heartwood (SV810E, SV810UE), and solid titanium. The supple yet durable calfskin bellows are hand-made to Ebony's specifications. The hand-strap is made of genuine cordovan leather. The SV810U and SV810UE feature asymmetrical tilts and swings on the back standard for easier and faster focusing.

- Extremely rigid construction: no vibration or sway, even at maximum extension. Complete stability is assured.
- The movements, precision and rigidity of a view camera with the portability of a field camera
- Base and center tilts at both front and back (Asymmetrical tilts and swings replace center tilts and swings on back standard of SV810U and SV810UE allowing perfect focus to be maintained during adjustments.)
- Enormous, triple-draw bellows extension, enabling use of 90mm to 1200mm lenses. (Interchangeable wide-angle bellows available as optional accessory)
- Compatible with Sinar-type lensboards, Linhof adapter board included
- Foldable, with 30° bed drop
- Accepts both 4x5 International Standard and 6x9 Graphic Standard roll film holders (Horseman, Mamiya RB67 etc.) with 8x10->4x5 reducing back: format reducing adapter required for 6x9 roll film or instant film holders.

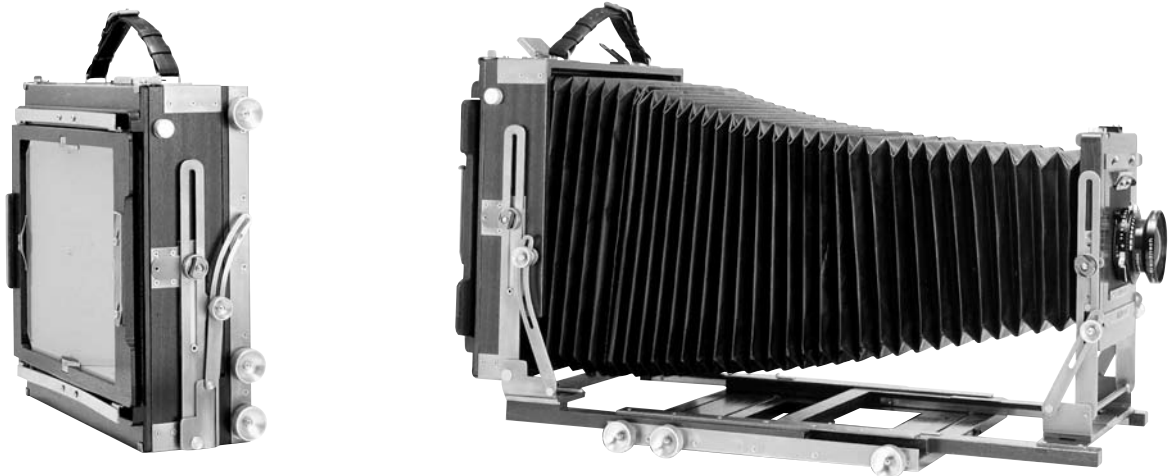

SPECIFICATIONS

CAMERA TYPE		Folding view camera	
FORMAT		International Standard 8x10 inch	
CONSTRUCTION MATERIALS		Mahogany (SV810, SV810U) or ebony (SV810E, SV810UE) and titanium	
FOCUSING SYSTEM		Triple-draw rack and pinion (front and back focusing)	
LENSBOARD		Sinar-type (Linhof adapter board included)	
CAMERA BACK		Interchangeable vertical/horizontal International Standard	
FOCUSING SCREEN		Ground glass with 10mm grid	
MOVEMENTS (levers lock swings and shifts, knobs lock all other movements)	FRONT	Rise 80mm, Fall 30mm, Shift 50mm+50mm, Swing 20°+20°, Base tilt forward 30°, backward 90°, Center tilt 30° + 30°	
	BACK	SV810U	Rise 80mm, Asymmetrical swing 20°+20°,
		SV810UE	Base tilt forward 90°, backward (bed drop) 30°, Asymmetrical tilt 20° + 20°
	BED	SV810	Rise 80mm, Swing 20°+20°,
SV810E		Base tilt forward 90°, backward (bed drop) 30°, Center tilt 20° + 20°	
ZERO ("NULL") POSITION RESET		Front swings and center/asymmetrical tilts: zero detents Back rise: lowest position Front rise/fall: zero position alignment points Shifts: zero position on scale Base tilts: zero position notches	
MIN/MAX BELLOWS EXTENSION		125mm (70mm with tilts and rise) - 850mm (1000mm with tilts and rise)	
USABLE LENSES		90mm - 1200mm (telephoto)	
SPIRIT LEVEL	FRONT	One-way	
	BACK	Two-way with mirror	
WEIGHT / DIMENSIONS	SV810U	5.0 kg / 31.5 (h) x 34.0* (w) x 11.5 (l) cm	
	SV810UE	6.5 kg / 31.5 (h) x 34.0* (w) x 11.5 (l) cm	
	SV810	5.0 kg / 31.5 (h) x 34.0* (w) x 11.5 (l) cm	
	SV810E	6.5 kg / 31.5 (h) x 34.0* (w) x 11.5 (l) cm	*including knobs

* Model depicted: SV810

NEW EBONY SW810 series*

A lightweight non-folding view camera, specifically designed for use with wide-angle lenses, featuring an extensive range of movements. Uniquely thin and supple yet durable calfskin bellows allow full movements with even the widest lenses without causing bellows shadow. A favourite of architectural photographers. Constructed entirely of quarter-sawn Honduran mahogany heartwood (SW810), or quarter-sawn ebony heartwood (SW810E), and solid titanium.

- Absolutely rigid construction: no vibration or sway, even at maximum extension. Complete stability is assured.
- The movements, precision and rigidity of a view camera with the portability of a field camera
- Compatible with Sinar-type lensboards, Linhof adapter board included
- Accepts both 4x5 International Standard and 6x9 Graphic Standard roll film holders (Horseman, Mamiya RB67 etc.) with 8x10->4x5 reducing back: format reducing adapter required for 6x9 roll film or instant film holders



SPECIFICATIONS

CAMERA TYPE		Non-folding view camera	
FORMAT		International Standard 8x10 inch	
CONSTRUCTION MATERIALS		Mahogany (SW810) or ebony (SW810E) and titanium	
FOCUSING SYSTEM		Triple-draw rack and pinion (front and back focusing)	
LENSBOARD		Sinar-type (Linhof adapter-board included)	
CAMERA BACK		Interchangeable vertical/horizontal	
FOCUSING SCREEN		Ground glass with 10mm grid	
MOVEMENTS (levers lock swings and shifts, knobs lock all other movements)	FRONT	Rise 120mm, Fall 70mm, Shift 50mm+50mm, Swing 20°+20°, Center tilt 30°+30°	
	BACK	Rise 80mm, Swing 20°+20°, Center tilt 20°+20°	
ZERO ("NULL") POSITION RESET		Front swings and center tilts: zero detents Back rise: lowest position Front rise/fall: zero position alignment points Shifts: zero position on scale	
MIN/MAX BELLOWS EXTENSION		105 - 380mm	
USABLE LENSES		90mm - 360mm	
SPIRIT LEVEL	FRONT	One-way	
	BACK	Two-way with mirror	
WEIGHT / DIMENSIONS		SW810	4.0 kg / 37.0 (h) x 35.0* (w) x 16.0 (l) cm
		SW810E	5.2 kg / 37.0 (h) x 35.0* (w) x 16.0 (l) cm

* Model depicted: SW810

EBONY SW45/SW23

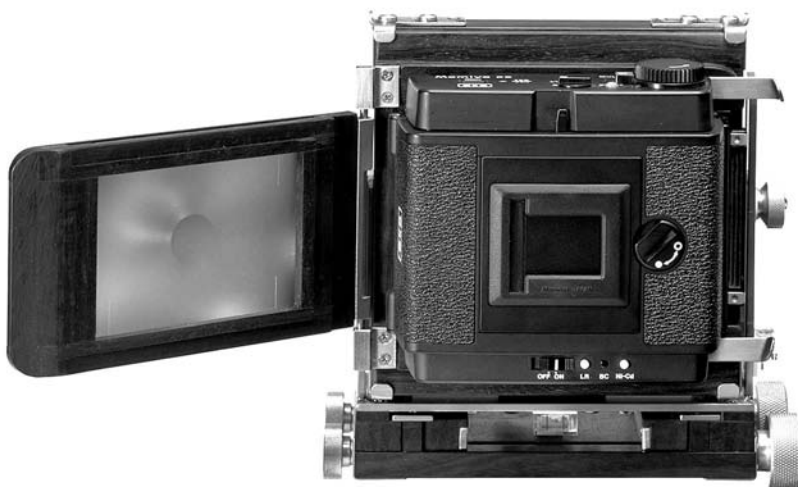
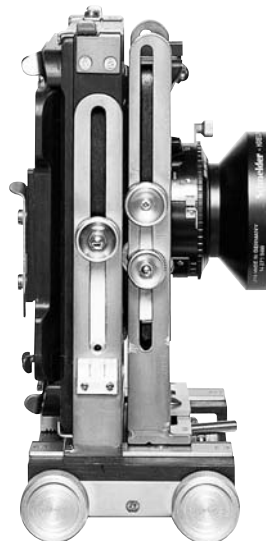
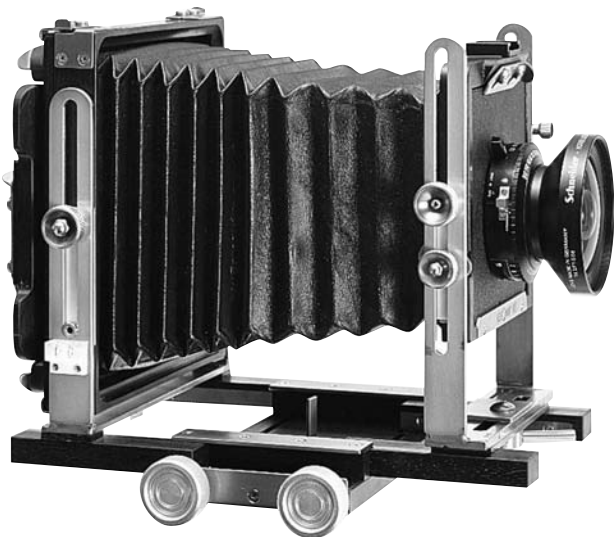

Back Movements

Rise SW45: 50 mm
SW23: 42 mm

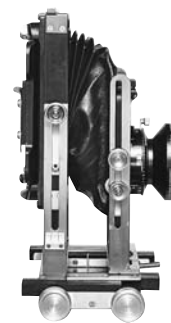

6x9 roll film holders may be removed without dismounting focusing screen.
When using format reducing adapter with 4x5 back, flange back is increased by 6mm.

Front Movements

Rise SW45: 65 mm
SW23: 45 mm
Fall SW45: 25 mm
SW23: 16 mm

Shift 38 mm + 38 mm

Swing 45° + 45°

Center tilt 20° + 20°



EBONY SW45/SW23

An extremely lightweight non-folding view camera, specifically designed for use with wide-angle lenses. Uniquely supple calfskin bellows allow full movements with even the widest lenses without causing bellows shadow. A favourite of architectural photographers. Constructed entirely of quarter-sawn ebony heartwood and solid titanium. Optional extension backs 452 (for SW45) and 692 (for SW23) and/or extension tubes enable the use of longer lenses.

- Absolutely rigid construction: no vibration or sway, even at maximum extension. Complete stability is assured.
 - 35mm lens usable with recessed lensboard, 38mm lens usable with flat board, without restricting movements.
 - Light, versatile, easy to use
 - Compatible with Linhof-type 4x5 lensboards
- **SW45 accepts both 4x5 International Standard and 6x9 Graphic Standard roll film holders (Horseman, Mamiya RB67 etc.): format reducing adapter required for 6x9 roll film or instant film holders.**
 - **SW23 accepts 6x9 Graphic Standard roll film holders (Horseman, Mamiya RB67 etc.): roll film holders may be removed without dismounting focusing screen.**
 - **6x9 Polaroid/Fuji film may be used with Instant Film Holder GP (available as optional accessory).**

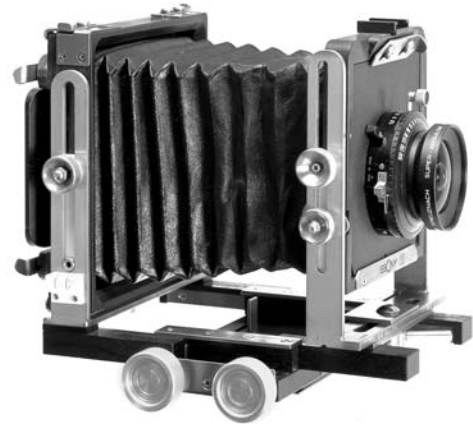

SPECIFICATIONS

	SW45	SW23
CAMERA TYPE	Non-folding view camera	
FORMAT	International Standard 4x5 inch. Accepts all International Standard sheet film holders: Polaroid 405, 545, 550, Fuji Instant MS45, PA45, and all Graphic Standard roll film holders.	Graphic Standard 6 x 9 cm (2 x 3 inch). Accepts all Graphic Standard roll film holders.
CONSTRUCTION MATERIALS	Ebony and titanium	
FOCUSING SYSTEM	Triple-draw rack and pinion (front and back focusing)	
LENSBOARD	4x5 Linhof-type	
CAMERA BACK	Interchangeable vertical/horizontal International Standard	Interchangeable vertical/horizontal Graphic Standard
FOCUSING SCREEN	Fresnel lens with 10mm grid, protective glass	
MOVEMENTS (levers lock swings and shifts, knobs lock all other movements)	FRONT	Rise 60mm, Fall 25mm, Shift 38mm+38mm, Swing 45°+45°, Center tilt 20°+20°
	BACK	Rise 50mm
ZERO ("NULL") POSITION RESET	Swings and center tilts: zero detents Back rise: lowest position Front rise/fall: zero position alignment points Shifts: zero position on scale	
MIN/MAX BELLOWS EXTENSION	46mm - 190mm	46mm - 157mm
USABLE LENSES	35mm* - 180mm, (250mm, 400mm telephoto with extension back 452) * 35mm lenses require recessed lensboard	35mm* - 150mm, (250mm, 400mm telephoto with extension back 692) * 35mm lenses require recessed lensboard
SPIRIT LEVEL	Two one-way levels on back standard	
WEIGHT / DIMENSIONS	1.5kg / 21.0 (h) x 20.5* (w) x 9.0 (l) cm *including knobs	1.3kg / 17.0 (h) x 17.5* (w) x 8.0 (l) cm *including knobs

EBONY RW45

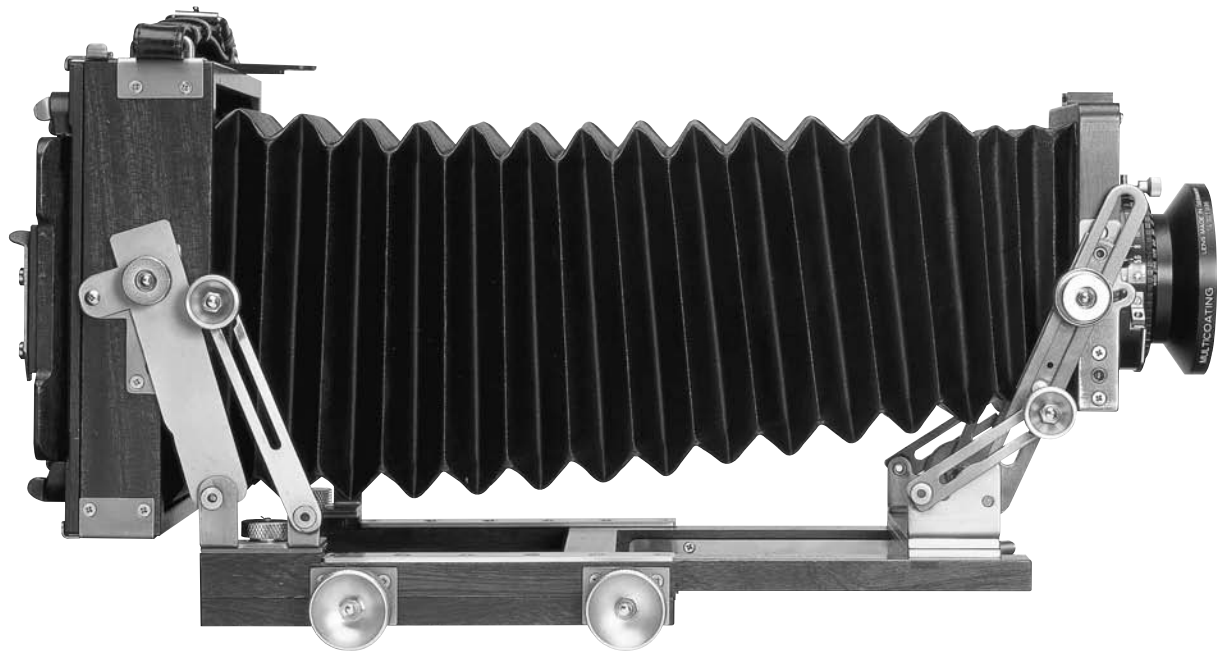

395mm maximum extension (including tilts)

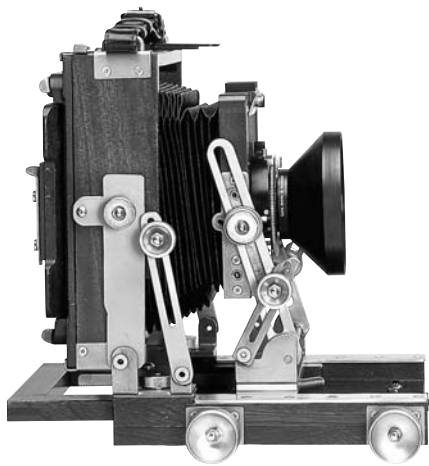

65mm and 75mm lenses may be used

Front Movements

Rise 45 mm, Fall 20 mm

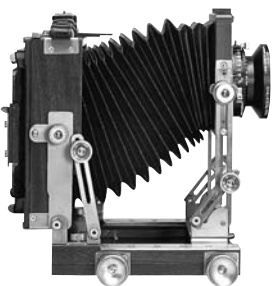

Swing 20° + 20°

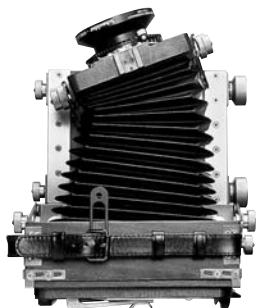

Base tilt forward 25°, backward 90°

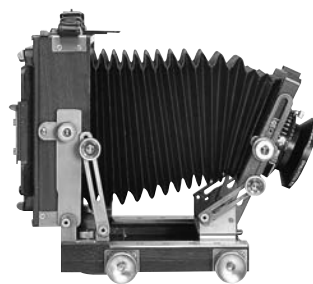

Center tilt 30° + 30°

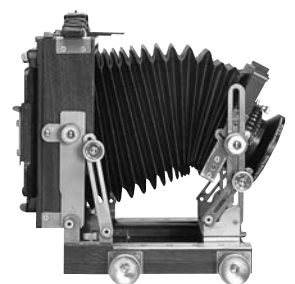

EBONY RW45

A lightweight folding view camera particularly suited to landscape work. Constructed entirely of quarter-sawn Honduran mahogany heartwood, aged for over 20 years, and finished with exquisite Lacquer Japan ('urushi'). Solid titanium is used for the metal parts. Precision-made to the same standards as the SV45Ti, but with a simpler range of movements for greater ease of use.

- Mahogany and titanium construction: no vibration or sway, even at maximum extension. Complete stability is assured.
 - Light, versatile, easy to use
 - Accepts Linhof-type 4x5 lensboards
 - For longer lenses Ebony extension tubes may be used.
- Accepts both 4x5 International Standard and 6x9 Graphic Standard roll film holders (Horseman, Mamiya RB67 etc.): format reducing adapter required for 6x9 roll film or instant film holders.

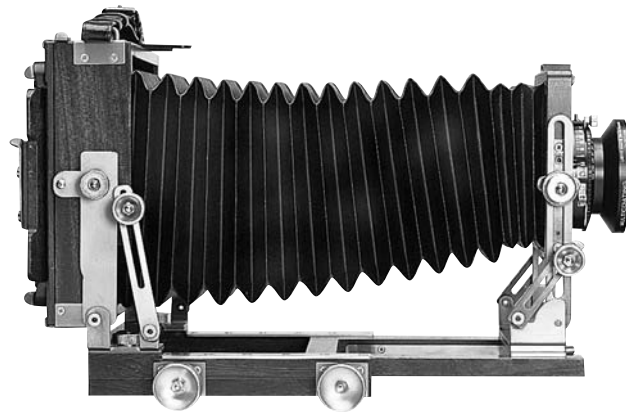

SPECIFICATIONS

CAMERA TYPE		Folding view camera
FORMAT		International Standard 4x5 inch. Accepts all International Standard sheet film holders: Polaroid 405, 545, 550, Fuji Instant MS45, PA45, and all Graphic Standard roll film holders.
CONSTRUCTION MATERIALS		Mahogany and titanium
FOCUSING SYSTEM		Double-draw rack and pinion
LENSBOARD		4x5 Linhof-type
CAMERA BACK		Interchangeable vertical/horizontal International Standard
FOCUSING SCREEN		Fresnel lens with 10mm grid, protective glass
MOVEMENTS (levers lock front swings, knobs lock all other movements)	FRONT	Rise 45mm, Fall 20mm, Swing 20°+20°, Base tilt forward 25°, backward 90°, Center tilt 30° + 30°
	BACK	Swing 10°+10°, Base tilt forward 90°, backward (bed drop) 20°, Center tilt 20°+20°
	BED	Drop 20°
ZERO ("NULL") POSITION RESET		Center tilts/Front swings: zero detents Front rise/fall: zero position alignment points Base tilts: zero position notches
MIN/MAX BELLOWS EXTENSION		93mm (60mm with tilts) - 325mm (395mm with tilts)
USABLE LENSES		65mm - 500mm (telephoto)
WEIGHT / DIMENSIONS		1.7kg / 19 (h) x 21* (w) x 10 (l) cm *including knobs

Back Movements

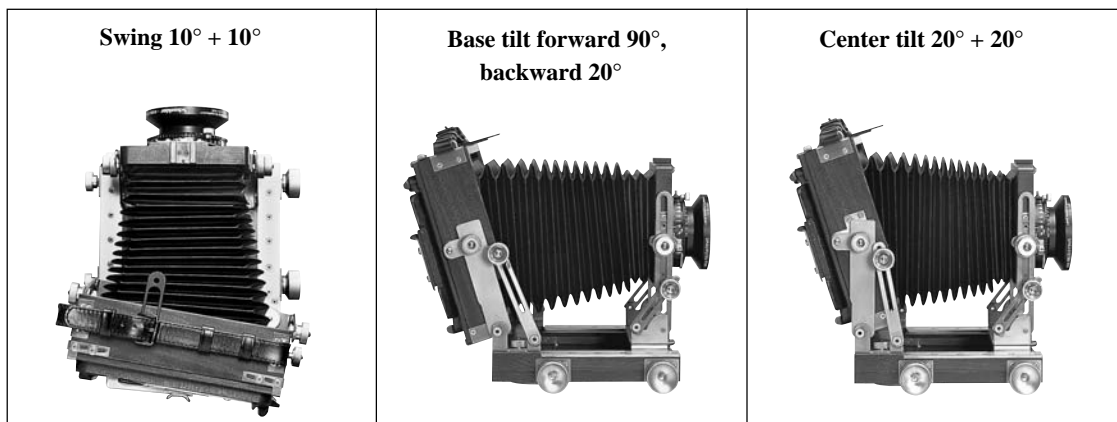

— EBONY ACCESSORIES —

(BELLOWS INCLUDED WITH EVERY CAMERA, AND FRESNEL LENS WITH ALL 4X5 AND 6X9 CAMERAS)

<http://www.ebonycamera.com/acc.html>

ACCESSORY NAME	APPLICABLE CAMERA(S)
Wide-angle bellows	All SV cameras, 45SU
Replacement standard bellows (4x5)	SV45TE/Ti
Interchangeable universal bellows (4x5)	SV45U2, SV45U, SV45TE/Ti, 45SU
Fresnel lens (with grid)	All 4x5/6x9 backs
Wide-angle Fresnel lens	All 4x5/6x9 backs
Protective glass	All 4x5/6x9 backs
Instant film holder GP	23S, SW23
Instant film holder for format reducing adapter	All 4x5 backs with format reducing adapters
Format reducing adapter 4x5->6x9 (mahogany)	All 4x5 backs
Format reducing adapter 4x5->6x9 (ebony)	All 4x5 backs
Reducing back 8x10->5x7	All 8x10 backs
Reducing back 8x10->4x5	All 8x10 backs
Reducing back 5x7->4x5	All 5x7 backs
Extension back 452 (90mm, plus 10° tilt)	45SU, 45S, SW45 (only available with new camera)
Extension back 692 (90mm, plus 10° tilt)	23S, SW23 (only available with new camera)
Extension tube kits (17mm, 35mm)	All camera lenses with Linhof-type lensboard
Lens box	All camera lenses with Linhof-type lensboard
Lens shade clip	All cameras
Bellows-type focusing hood	All 4x5 cameras
Regular focusing cloth	All cameras
All-weather focusing cloth (1.5 m ² , requires lens shade clip)	All cameras
Lensboards (Linhof-type, aluminium and ebony) Copal #0, #1, #3	All 4x5/6x9 cameras



Format reducing adapter 4x5->6x9

The format reducing adapter may be used with all International Standard 4x5 backs. (Flange back is increased by 6mm.) 6x9 roll film holders may be removed without dismounting the focusing screen.

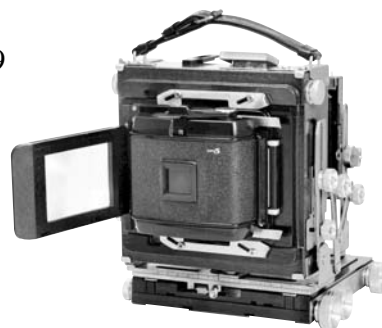

All-weather focusing cloth (requires lens shade clip)

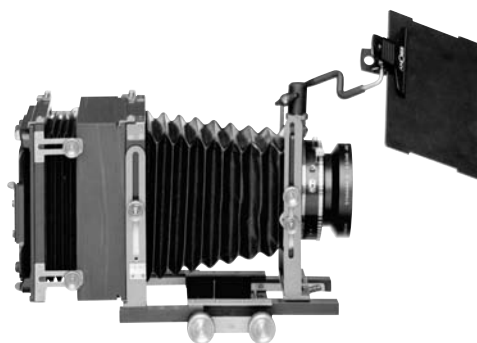

SW45 with extension back 452 and lens shade clip



17mm and 35mm extension tubes

EBONY CO., LTD.

Shin Oyama Building, 1st Fl.,
38-12 Oyama Kanai-cho,
Itabashi-ku, Tokyo 173-0024, Japan
Tel: +81-3-3972-3170
Fax: +81-3-5995-3738

E-mail hiromi@ebonycamera.com
Web Site www.ebonycamera.com